

1 General Description

The NB1042AS is a reference design that can be used as an example to develop a self-contained GPS receiver module based on the Nemerix NJ1030A and NJ1006A GPS chipset. The receiver embeds the flash memory necessary to store the Nemerix NS1030 GPS firmware and provides the phantom power for the required, external active antenna. It is built with 0.5mm pitch μ BGA devices in order to achieve a very compact design.

The NB1042AS interfaces to the host system via the NJ1030A UART using the NMEA protocol expanded with Nemerix specific commands. It requires a 3.3V main power supply and a back-up voltage of 1.2V to 2V to maintain relevant GPS and system information in the non volatile portion of the NJ1030A memory.

The NB1042AS is delivered with a 4MBit Flash device and a 32.734MHz TCXO. Other configurations are possible.

1.1 Features

- GPS receiver module with active antenna support
- Based on NJ1030A and NJ1006A chipset
- Low power consumption: 19mA fully active
- Compact design: 22.5x25.3x3.5mm
- SMT compliant
- UART interface
- μ BGA 0.5mm pitch components
- Support of WAAS/EGNOS (SW option)
- Support of 4Mbit and 8Mbit flash
- Support of 16.367MHz and 32.734MHz TCXO

Figure 1: NB1042AS Block diagram

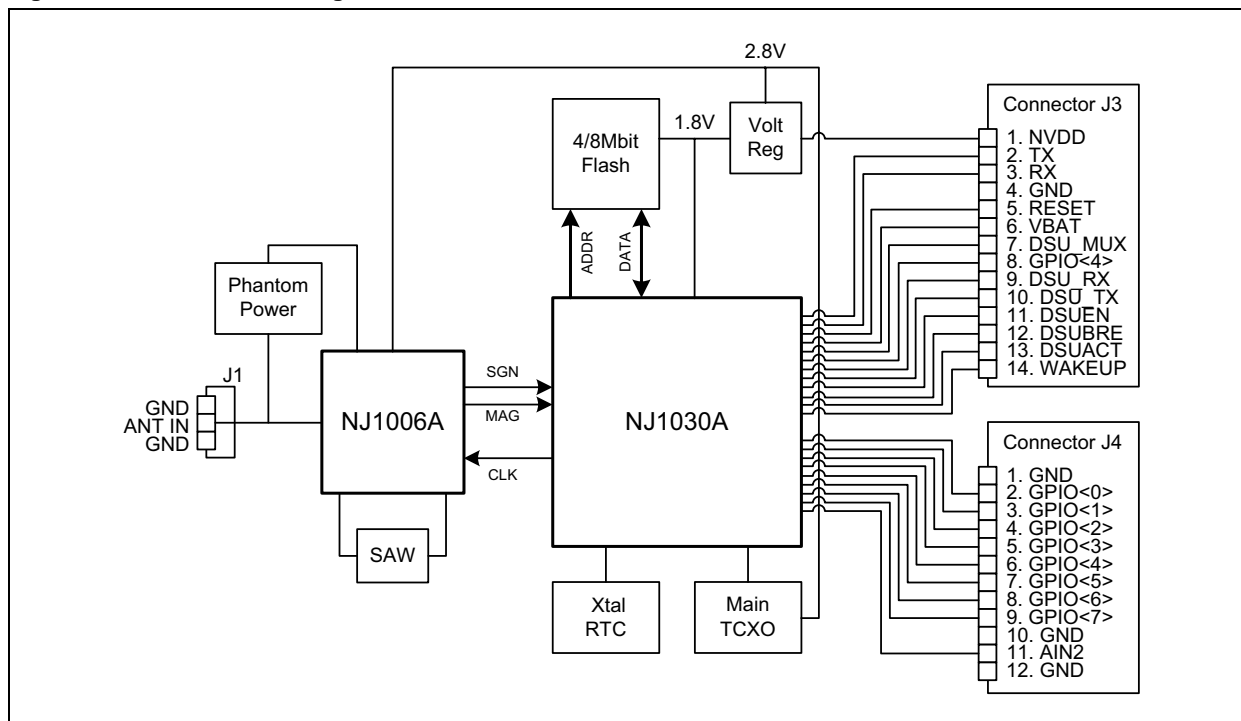

1.2 Specifications

Parameter	Min	Typical	Max
Main supply voltage (NVDD)	3V	3.3V	6V
Back up power supply voltage (VBAT)	1.2V		2V
Operating Temperature	-30°C		+65°C
Power Consumption in acquisition (fully active)		23mA	
Power Consumption in tracking (fully active)		19mA	
Active antenna phantom power voltage		2.8V	
Active antenna phantom power current	2mA		20mA
GPS Channels		16	
Tracking sensitivity	-150dBm		
TTF Cold Start @ -135 dBm		46 sec	
TTF Warm Start @ -141 dBm		34 sec	
TTF Hot Start @ -141 dBm		5 sec	
Re-acquisition time @ -147 dBm		< 3 sec	
Update rate		1 Hz	

Frequency	1575.42MHz - L1 C/A Code
I/O Port	UART interface
Protocol	NMEA (Extended)
Weight	3g
Mating Connector	14 pin and 12 pin 1.27mm pitch headers
Dimensions	22.5x25.3x3.5 mm

2 Communication Protocol

The communication protocol is the standard NMEA expanded with Nemerix commands.

3 NB1042AS Receiver Parts

3.1 Antenna

An active antenna must be connected to connector J10. A phantom power (2.8V) is provided for the LNA of the active antenna. The antenna current can be in the range 2-20mA. Outside of this range the antenna detector on NJ1006A will report a failure (for more details see the NJ1006A datasheet).

3.2 NJ1006A front end

The NJ1006A is the down-converter (see related datasheet). Power supply for the NJ1006A is set to 2.8V (AVDD) with a low dropout regulator. To reduce overall size, the Toyocom TQS-949FA 2x2.5x1mm L1 SAW filter is used.

A single stage cascode integrated LNA with 20dB gain and 3dB NF has been used for best impedance matching for the active antenna.

3.3 NJ1030A base-band

The GPS base-band processor is the NJ1030A. It is used in its minimum configuration, i.e. only as GPS processor (see related datasheet). The only required external part is the flash memory storing the NS1030 GPS firmware. Power supply is set to 1.8V (DVDD) with a linear regulator. Supply voltage for the core is set to 1.2V using the on-chip regulator. Communication to the NJ1030A is provided via the UART.

3.4 Flash Memory

A 4Mbit (optional 8Mbit) organized in 256k (512k) x 16bit flash memory is needed by the NJ1030A IC. SST39WF400A (SST39WF800A) is an adequate flash for this application. It operates from DVDD and comes in a 4x6mm (5x6mm) μ BGA package.

A different flash memory type can be used, as long as it is pin compatible with the memories described here. The voltage supply must be in the NJ1030A DVDD specification (1.8V-3.3V) and the dual voltage regulator (part U1) must be changed accordingly.

Note: the NB1042AS is delivered with 4Mbit SST flash device as default configuration. Any change of the flash configuration may require a different flash programmer configuration (refer to the flash programmer documentation). Flash memory access time shall be 90 ns or lower.

3.5 Clock

The clock frequency is set to 32.734MHz and is generated by a TCXO. The recommended TCXO is the Rakon IT5325B. It has 2.0ppm accuracy over temperature, a size of 5x3.2x1.5mm and requires a minimum voltage supply of 2.7V. The TCXO is sensible to power supply noise, therefore the AVDD power supply of the RF front-end is used. The use of a 16.367MHz TCXO is also possible in the design, if the WAAS/EGNOS functionality is not enabled in the GPS software.

Note: the NB1042AS is delivered with 32.734MHz TCXO as default configuration. If a 16.367MHz TCXO is used, a different NS1030 SW build is necessary. Also the configuration of the flash programmer must be adapted accordingly (see dedicated documentation).

3.6 RTC and Battery Backup

The NJ1030A includes a real time clock and 8kB NVRAM. This allows time and navigation database to be maintained when the NB1042AS is powered down. The RTC crystal is a tuning fork type, 32.768kHz crystal. A Microcrystal CC5V-T1A in a 4.1x1.5mm package is the selected crystal.

RTC and NVRAM require a supply voltage of 1.2V to 2V. Power must be provided via VBAT pin on the interface connector. Any 1.2-1.5V battery or a super-capacitor can be used. If a rechargeable battery or a super-capacitor are used, a charge circuit must be provided. This may consist of a simple resistor-diode circuit. A mean to limit charge voltage below 2V should be included if the battery can be removed while the main power is on.

A suitable battery is the Varta V15H NiMH 1.2V rechargeable battery. This battery has a capacity of 15mAh and a size of 11.5mm(diameter)x3mm(height). It can be recharged at 1.8mA via a simple diode-resistor network. If the back-up voltage is not present RTC and NVRAM do not work. As a consequence the receiver will always execute a cold start when activated.

3.7 Voltage Regulator

A dual voltage regulator generates two voltage supply (AVDD and DVDD) from the main voltage supply (NVDD). AVDD is 2.8V and provides voltage to the NJ1006A and the TCXO. DVDD is 1.8V and provides voltage to the NJ1030A and the flash memory. Power for the NJ1030A core is obtained with the on-chip voltage regulator and it is set to 1.2V.

4 Interface Ports

Communication to the NB1042AS is provided via two connectors.

4.1 Connector J3

Connector J3 is a serial interface at 1.8V voltage level. A 14 pin 1.27mm pitch through hole connector is used. The pinout is shown in Table 1.

Pin 8 (GPIO[4]) is a pin that can be used to monitor NB1042AP status. It blinks for 1ms every time that some traffic is generated on the UART interface. It can be left unconnected if desired.

The interface on the J3 connector allows the user to download the firmware and debug the software by accessing the debugging unit of the NJ1030A (DSU). Firmware can be downloaded in the flash by using the interface board IB2000. Details on flash programming are available in the IB2000 datasheet.

Table 1. Interface connector J3

Pin #	Description
1	NVDD (3.3V)
2	NMEA TX
3	NMEA RX
4	GND
5	Reset
6	VBAT
7	DSU_MUX
8	GPIO[4]
9	DSU_RX
10	DSU_TX
11	DSU_EN
12	DSU_BRE
13	DSU_ACT
14	WAKEUP

4.2 Connector J4

On connector J4 the NJ1030A 8 GPIO signals are available at 1.8V voltage level. The analog input signal to A/D Converter AIN[2] is also available. A 12 pin 1.27mm pitch through hole connector is used. The pinout is shown in Table 2.

Table 2. Interface connector J4

Pin #	Description
1	GND
2	GPIO[0]
3	GPIO[1]
4	GPIO[2]
5	GPIO[3]
6	GPIO[4]
7	GPIO[5]
8	GPIO[6]
9	GPIO[7]
10	GND
11	AIN[2]
12	GND

The NB1042AS is also SMT compliant and can be mounted directly on the host PCB without the need of the connectors J3, J4 and J1.

Schematic Diagram (Continued)

Figure 3. Base band section schematic diagram

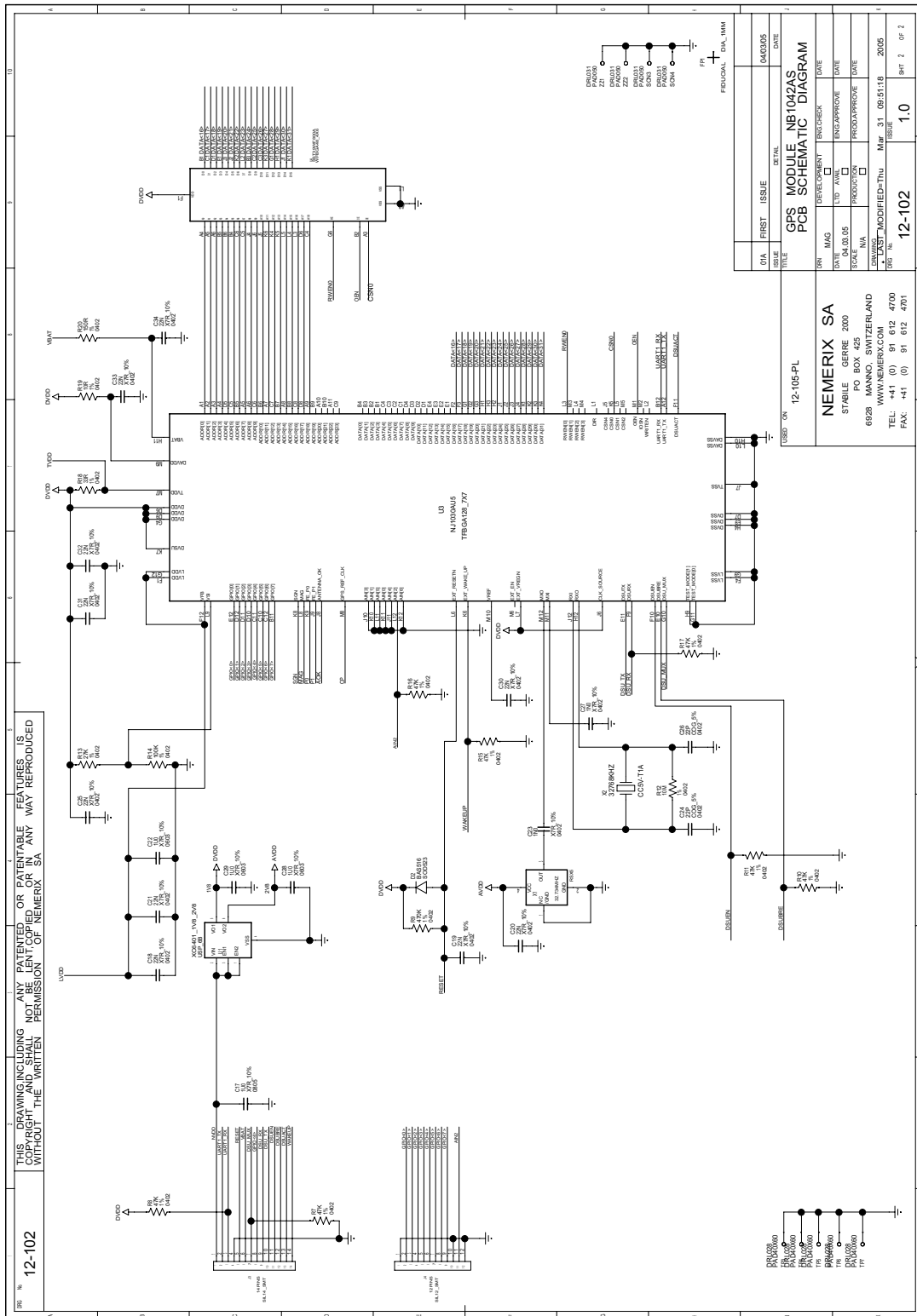

6. PCB Layout

Figure 4. PCB top assembly

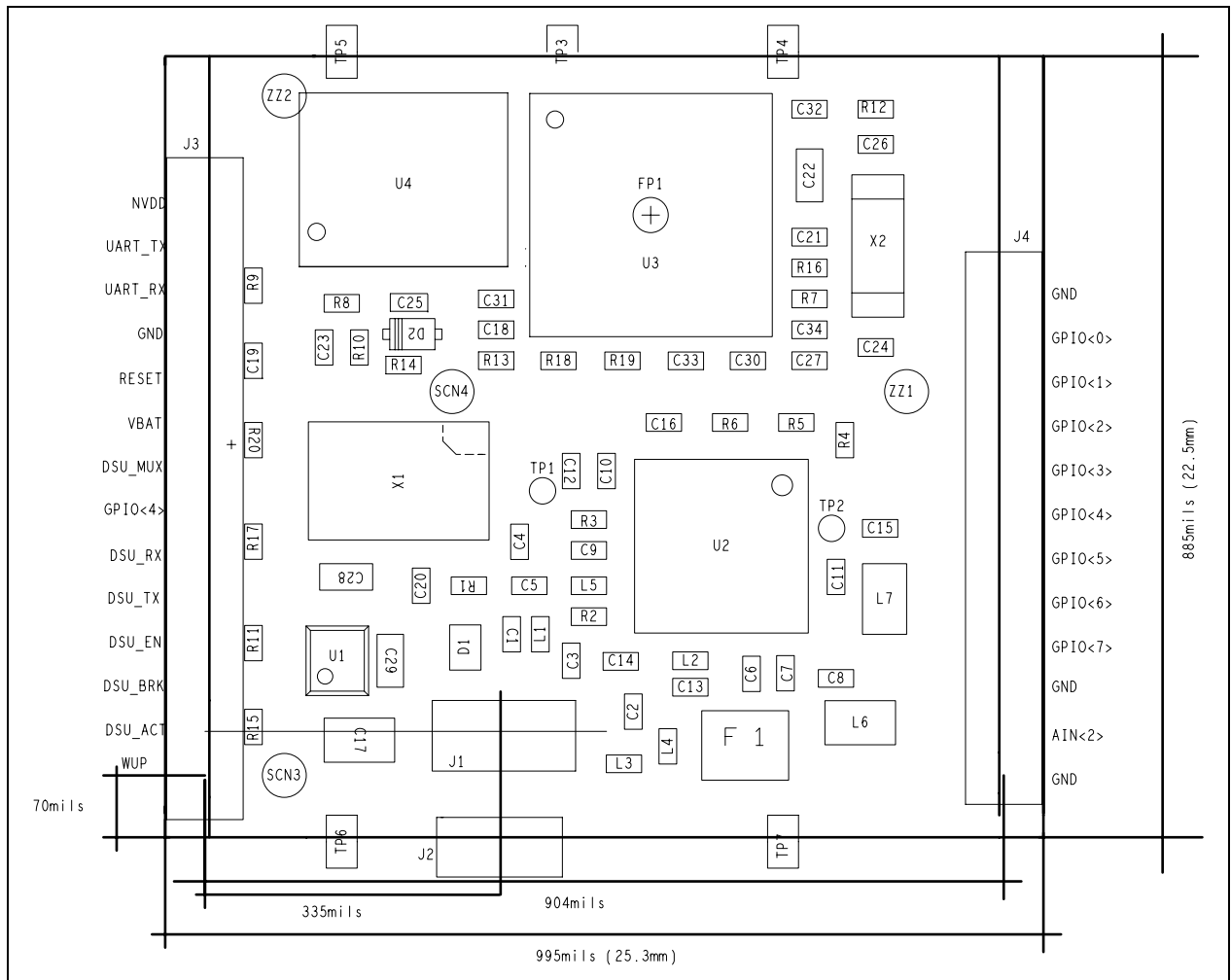

9 Bill of Material

Symbol	Type	Value	Size	Description
F1	Toyocom	TQS-949FA	2x2.5mm	GPS L1 SAW filter
J1	3x1 connector		1.27 mm pitch	Active antenna input pin header connector
(J2)	(3x1 connector)		1.27 mm pitch	(Active antenna input SMT connector, not mounted)
J3	14x1 connector		1.27 mm pitch	Power supply and interface connector
J4	12x1 connector		1.27 mm pitch	Interface connector
A1	Patch antenna		20x20mm	L1 passive patch antenna.
C1	COG	100pF	0402	LNA input coupling capacitor
C2	COG	100pF	0402	LNA output DC block capacitor
C3	COG	100pF	0402	NJ1006A antenna detector decoupling capacitor
C4	COG	2.2pF	0402	LNA input matching capacitor
C5	COG	100pF	0402	LNA input coupling capacitor
C6	COG	100pF	0402	Mixer input DC block capacitor
C7	X7R	100nF	0402	NJ1006A Band gap reference decoupling capacitor
C8 ³	COG	33pF ±5%	0402	IF filter first tank capacitor
C9	COG	470pF	0402	PLL loop filter capacitor
C10	X7R	100nF	0402	NJ1006A VB reference decoupling capacitor
C11 ³	COG	33pF ±5%	0402	IF filter second tank capacitor
C12	X7R	3.3nF	0402	PLL loop filter capacitor
C13	X7R	1nF	0402	Decoupling capacitor for AVDD power supply
C14	X7R	22nF	0402	Decoupling capacitor for AVDD power supply
C15	X7R	10nF	0402	AGC capacitor
C16	X7R	22nF	0402	TVDD decoupling capacitor.
C17	X7R	1uF	0805	Main NVDD decoupling capacitor
C18	X7R	22nF	0402	NJ1030A LVDD decoupling capacitor
C19	X7R	22nF	0402	NJ1030A reset capacitor
C20	X7R	22nF	0402	TCXO decoupling capacitor
C21	X7R	22nF	0402	NJ1030A LVDD decoupling capacitor
C22	X7R	1uF	0603	NJ1030A LVDD decoupling capacitor
C23	X7R	1nF	0402	TCXO coupling capacitor.
C24	COG	22pF	0402	RTC XTAL load capacitor
C25	X7R	22nF	0402	NJ1030A DVDD decoupling capacitor
C26	COG	22pF	0402	RTC XTAL load capacitor
C27	X7R	1nF	0402	NJ1030A MXI decoupling capacitor.
C28	X7R	1uF	0603	Main AVDD decoupling capacitor
C29	X7R	1uF	0603	Main DVDD decoupling capacitor
C30	X7R	22nF	0402	NJ1030A VREF decoupling capacitor
C31	X7R	22nF	0402	NJ1030A DVDD decoupling capacitor
C32	X7R	22nF	0402	NJ1030A DVDD decoupling capacitor
C33	X7R	22nF	0402	NJ1030A DAVDD decoupling capacitor
C34	X7R	22nF	0402	NJ1030A VBAT decoupling capacitor
D1	Philips	PESD3V3L2UM	SOT-883	Double ESD protection diode
D2	BAS516		SOD-523	Reset circuit diode
L1 ¹	Multi-layer	33nH ±10%	0402	Antenna phantom power inductor
L2 ¹	Multi-layer	33nH ±10%	0402	LNA output DC bias inductor
L3 ¹	Multi-layer	2.2nH ±0.3nH	0402	LNA output matching network inductor
L4 ¹	Multi-layer	3.3nH ±0.3nH	0402	LNA output matching network inductor
L5 ¹	Multi-layer	3.9nH ±0.3nH	0402	LNA input matching network inductor

L6 ²	Multi-layer	1.5uH ±10%	0805	IF filter first tank inductor
L7 ²	Multi-layer	1.5uH ±10%	0805	IF filter second tank inductor
R1	Chip	150R ±1%	0402	LNA input impedance matching resistor
R2	Chip	15R ±1%	0402	Antenna detector current sensing resistor
R3	Chip	6.8k ±1%	0402	PLL loop filter resistor
R4	Chip	390R ±1%	0402	NJ1006A SGN output damping resistor
R5	Chip	390R ±1%	0402	NJ1006A MAG output damping resistor
R6	Chip	390R ±1%	0402	NJ1006A CP input damping resistor
R7	Chip	47k ±1%	0402	NJ1030A DSU_MUX pull-down resistor
R8	Chip	47k ±1%	0402	NJ1030A UART_RX pull-up resistor
R9	Chip	470k ±1%	0402	Reset pull-up resistor
R10	Chip	47k ±1%	0402	NJ1030A DSUBRE pull-down resistor
R11	Chip	47k ±1%	0402	NJ1030A DSUEN pull-down resistor
R12	Chip	10M ±1%	0402	RTC oscillator bias resistor
R13	Chip	27k ±1%	0402	NJ1030A voltage supervisor resistor
R14	Chip	100k ±1%	0402	NJ1030A voltage supervisor resistor
R15	Chip	47k ±1%	0402	NJ1030A EXT_WAKE_UP pull-down resistor
R16	Chip	47k ±1%	0402	NJ1030A AIN[2] pull-down resistor
R17	Chip	47k ±1%	0402	NJ1030A DSURX pull-down resistor
R18	Chip	33R ±1%	0402	NJ1030A TVDD filter resistor
R19	Chip	10R ±1%	0402	NJ1030A AVDD filter resistor
R20	Chip	150R ±1%	0402	NJ1030A VBAT protection resistor
U1	Torex XC6401		USP-6B	Dual voltage regulator 1.8V/2.8V
U2	Nemerix NJ1006AM5	LPCC28	5x5 mm	Nemerix GPS front-end
U3	Nemerix NJ1030AU5	TFBGA128	7x7 mm	Nemerix GPS base-band processor
U4	SST39WF400AM1	WFBGA48	4x5 mm	4Mbit flash memory.
(U4)	(SST39WF800AM1)	(WFBGA48)	(4x6mm)	(8Mbit flash memory)
X1	Rakon IT5325BE		4PADS5032	32.734MHz 2ppm TCXO.
X2	MC CC5V-T1A		SMD4115XTAL	32.768kHz Crystal for RTC.

Note 1: Avoid using wire wound inductors; MuRata LQG15H series works well.

Note 2: Use only multilayer fully shielded inductors, e.g. MuRata LQG21N1R5K10. 5% tolerance is recommended for these inductors

Note 3: 2% tolerance is preferred, 5% is acceptable.

10. Notes

Ordering information

Part	Description
NB1042AS	GPS Engine Board

Related documentation

Part	Description
IB2000_ds10	IB2000 datasheet
NJ1006A_ds13	NJ1006A datasheet
NJ1030A_ds13	NJ1030A datasheet

Related products

Part	Description
IB2000	NB104xAx interface board
NJ1030AU5	GPS Baseband Processor BGA 7x7, 0.5mm pitch
NJ1030AU8	GPS Baseband Processor BGA 10x10, 0.8mm pitch
NJ1006A	GPS RF Front-End
EB1006AH11	NJ1006A GPS RF Front-End Evaluation board
DK1030A	Software Development Kit
NB1042AP	GPS receiver reference design with passive antenna

Nemerix SA
Headquarters
Stabile Gerre 2000
PO Box 425
6928 Manno
Switzerland

Phone +41 91 612 4700
Fax +41 91 612 4701
email sales@nemerix.com

LEGAL NOTICE:

NEMERIX PRODUCTS ARE NOT AUTHORIZED FOR USE AS CRITICAL COMPONENTS IN LIFE SUPPORT DEVICES OR IN APPLICATIONS WHICH INVOLVE POTENTIAL RISK OF DEATH, PERSONAL INJURY OR SEVERE PROPERTY OR ENVIRONMENTAL DAMAGE IN CASE OF FAILURE OR MALFUNCTION OF THE PRODUCT.



瑞士u-blox公司 全线产品代理

联系方式:



洪 维

King Hong

市场部

15012591515

飞扬科技(香港)有限公司
深圳市蝴蝶谷科技有限公司
Shenzhen Rise Technology co., LTD
地址: 深圳市福田区车公庙工业区201栋东座7楼
电话: 0755-81306214 传真: 0755-83318188
E-mail: GPSbaby@gmail.com http://www.GPSbaby.com

主要产品线:



U-blox 全系列GPS模块

U-blox GPS原装板卡/评估套件

U-blox GPRS模块



RISE-GPS系列u-blox GPS模块评估板
专业化成品GPS板卡



RISE-M系列GPS模块
大客户定制GPS解决方案



RISE 800MHz高速ARM11嵌入式CPU
支持DDR2代内存及H.264硬解压和2D及3D图形加速



MID及UMPC方案
PCBA方式及专业产品大客户定制模式



GPS电子罗盘成品
GPS导航仪, GPS电子警示器